

### Automatic Curved sliding door system CURVED Concave

**Design:**  
Fully automatic double-leaf curved convex sliding door with self-learning 32 bit door control system, low-noise, long-life door leaf guides, start impulse via motion detector; sensor protection incl. overcurrent detection; i-record connection via bluetooth

**Dimensions:**  
 Inside Radius IR : from 800 [mm]  
 Side part radius STR : IR+33 [mm]  
 Passage width A : from 1000 [mm]  
 Passage height G : 2200-3000 [mm]  
 Total height J : 2400-3300 [mm]  
 Profile system ALU 30 [mm]  
 The possibility of constructing a door with dimensions outside the specified ranges can be discussed individually

**Glass:**  
Profile system 30 [mm] - 19,52 [mm] max. glass thickness

- Glass types:
- Laminated safety glass
  - Insulated glass
  - P4A and P5A for RC2/RC3

BDE-D flush mount as standard

**Options:**

- Purposes:**
- Standard
  - Escape and rescue route

**Surface options:**

- Raw/untreated Aluminium
- Aluminium powder coating
- Anodized Aluminium
- Cladding (stainless steel/brass/bronze/etc.)

**Floor Guide:**

- Finished floor
- Floor guide rail
- Floor ring

**Mechanical options:**

- Air curtain (dependent on other options)
- Locking device
- Roof options:
  - White coated chipboard
  - Dust roof cover
  - Metal dust roof cover

**Electrical options:**

- Input for fire alarm
- Door position contact "closed"
- Lock monitoring contact
- Uninterrupted power supply
- LED build-in Lights
- Emergency stop switch
- Emergency opening switch
- Battery pack
- Control unit BDE-D surface mount (flush mount as standard)
- Key operating switch BDE-V

Surface treatment	Material	Remark
General tolerance	Proj. method	All components marked in green are to be checked before the customer!
ISO 2768	Scale 1:10	
	Drawn HNU	Date 2022-11-18
		Status Approved
		Rev. A
		Size A0
		Sheet 1 (3)
		Drawing No.



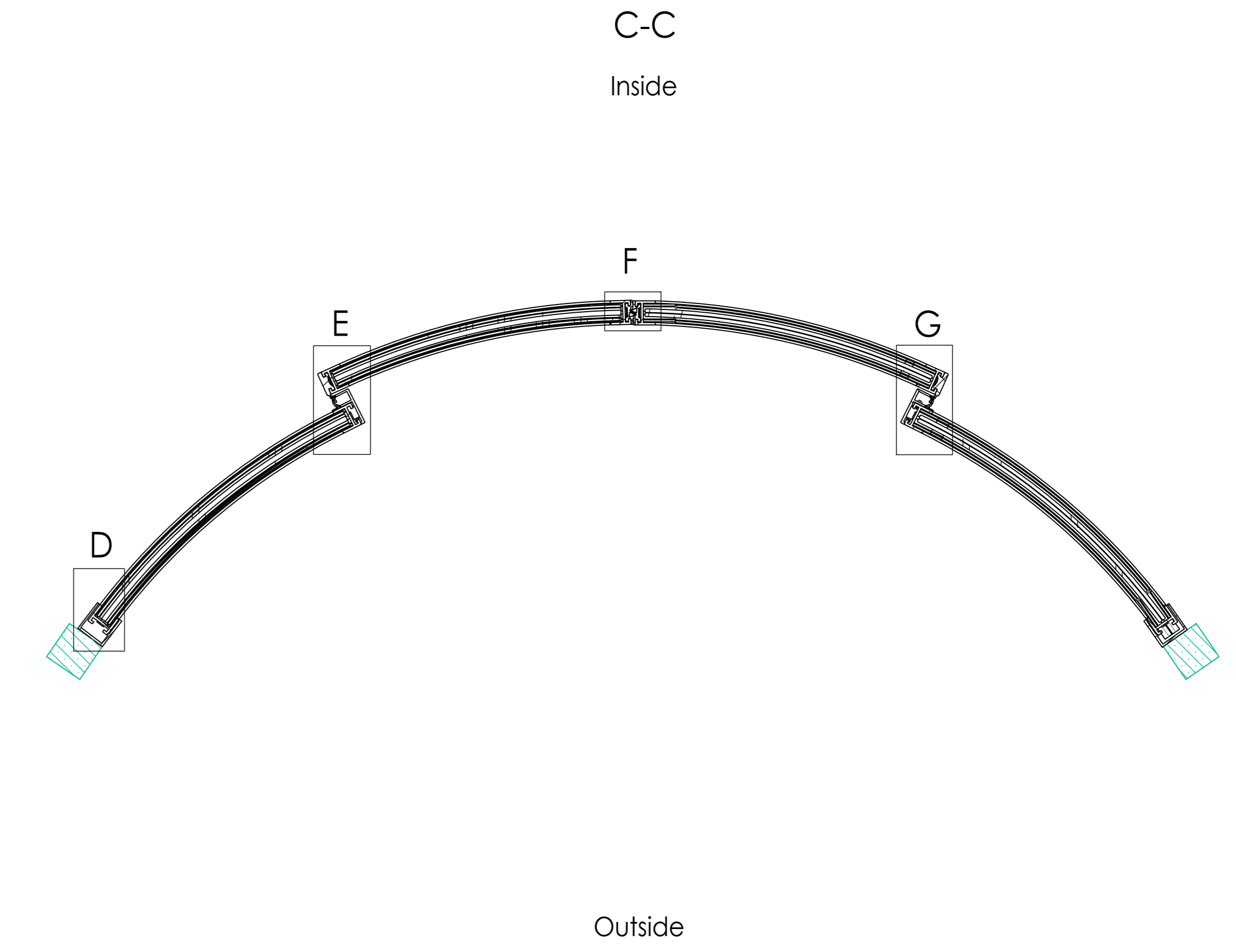
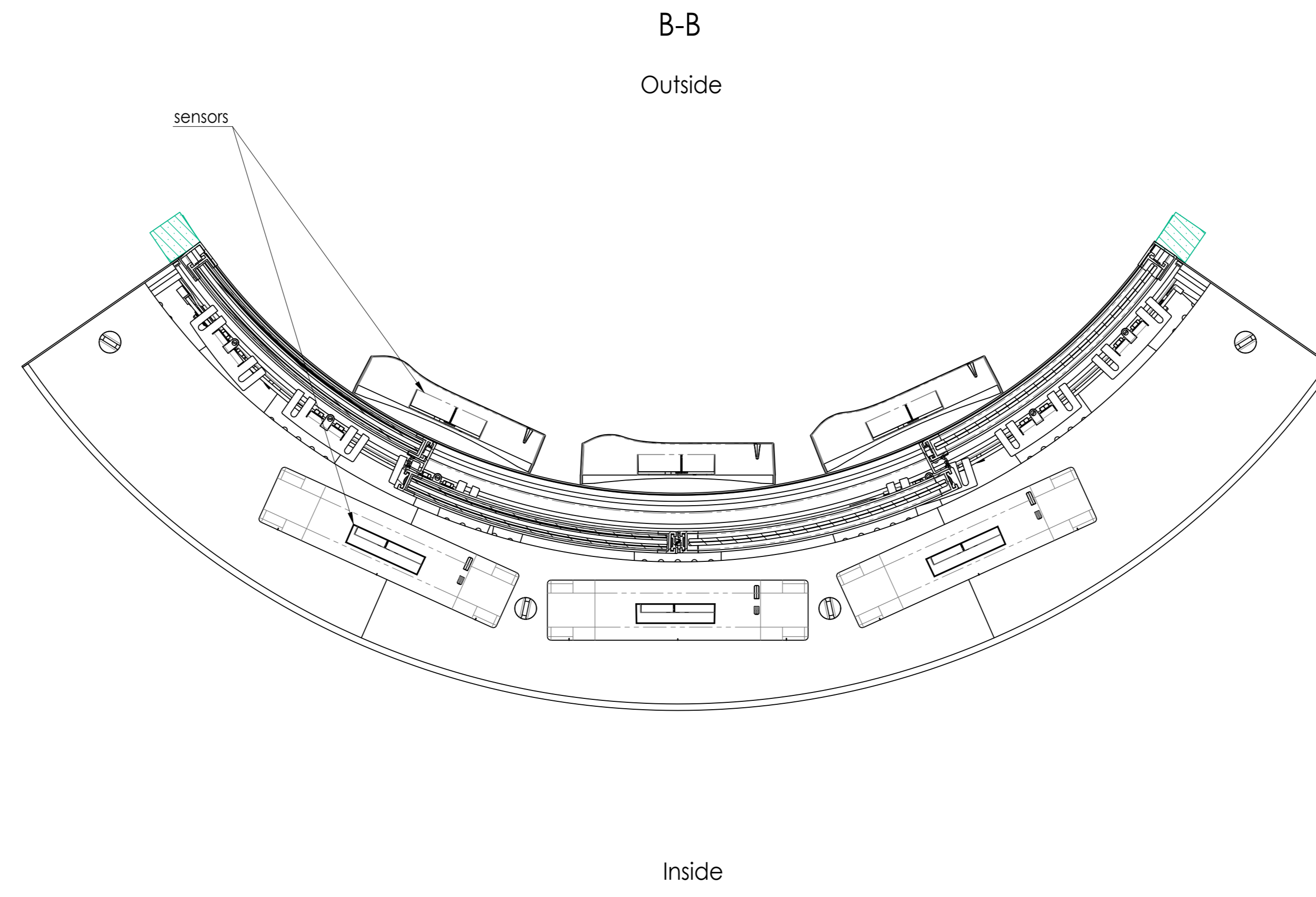
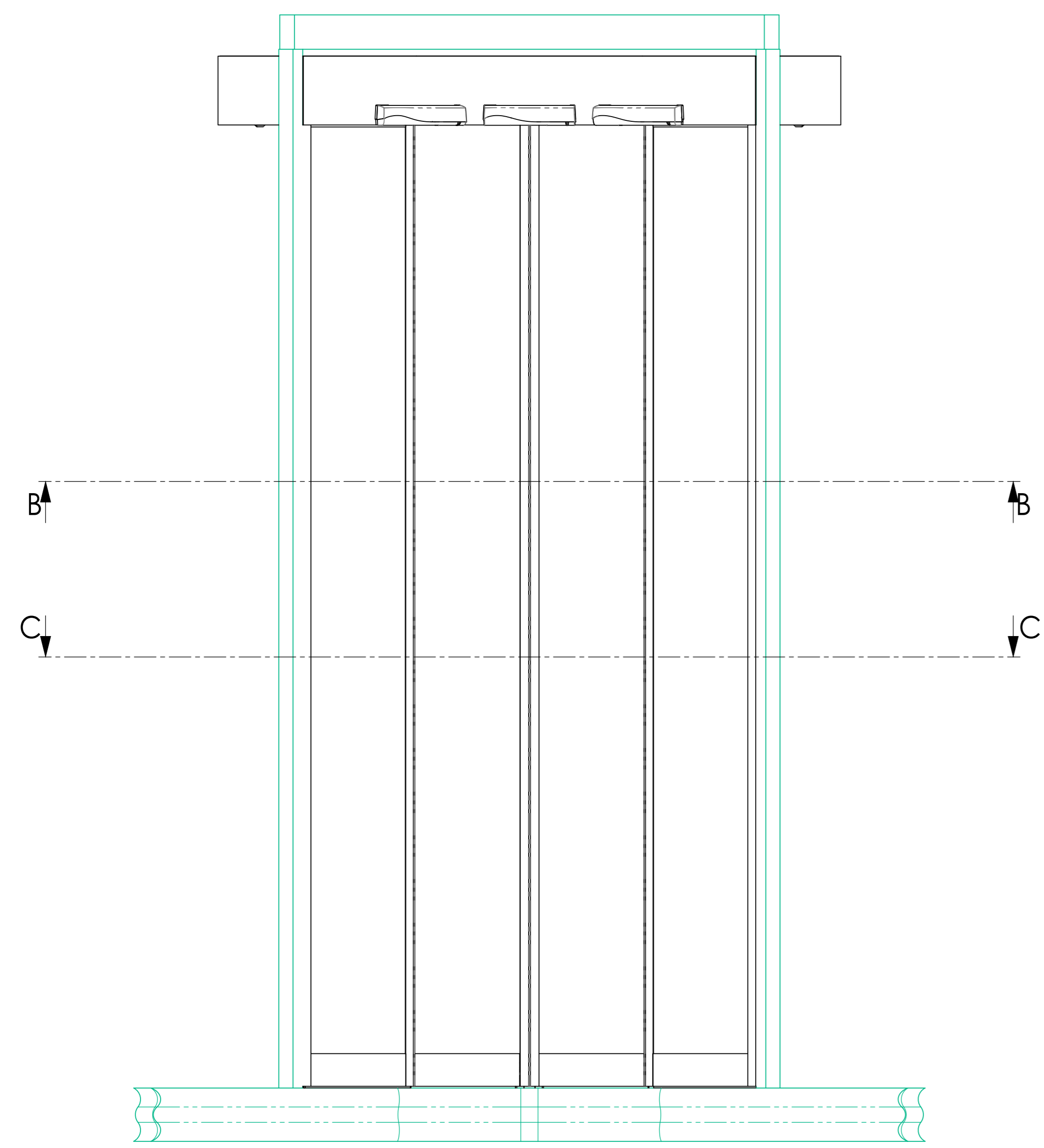

Main + Secondary closing edge

Example: Insulated glass, 19.52mm

Example: Laminated safety glass, 9.52mm

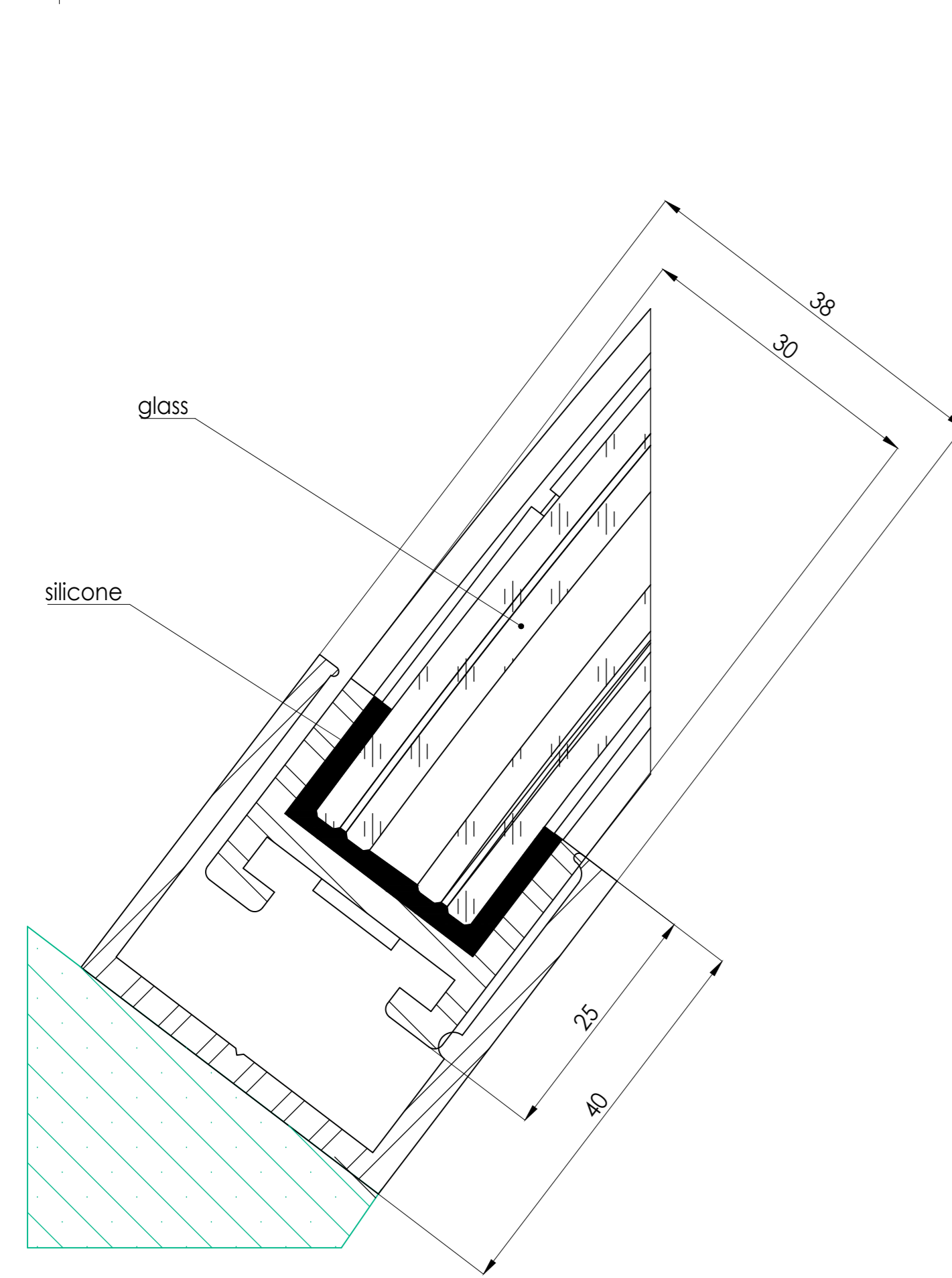

D  
(2:1)

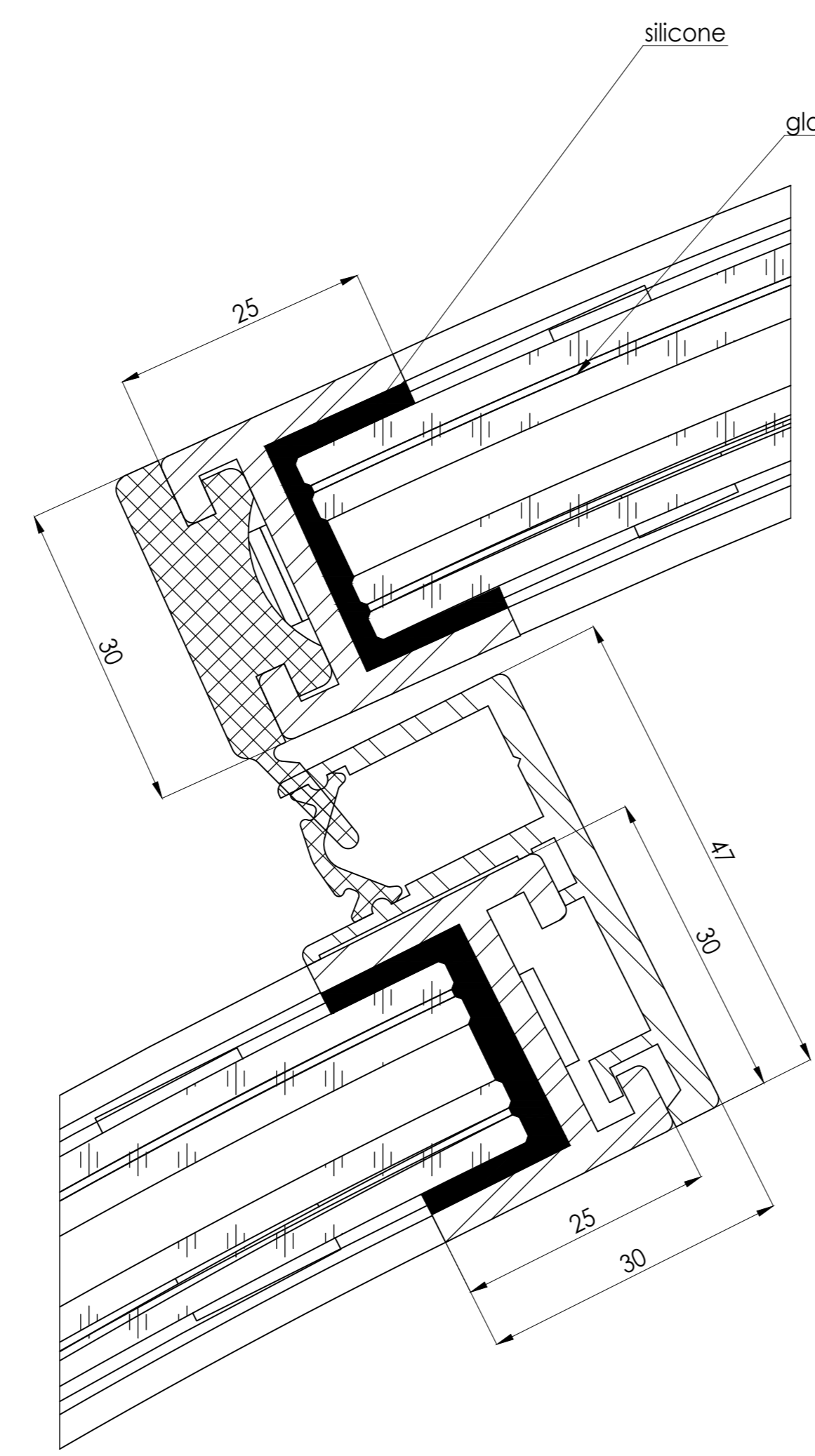

E  
(2:1)

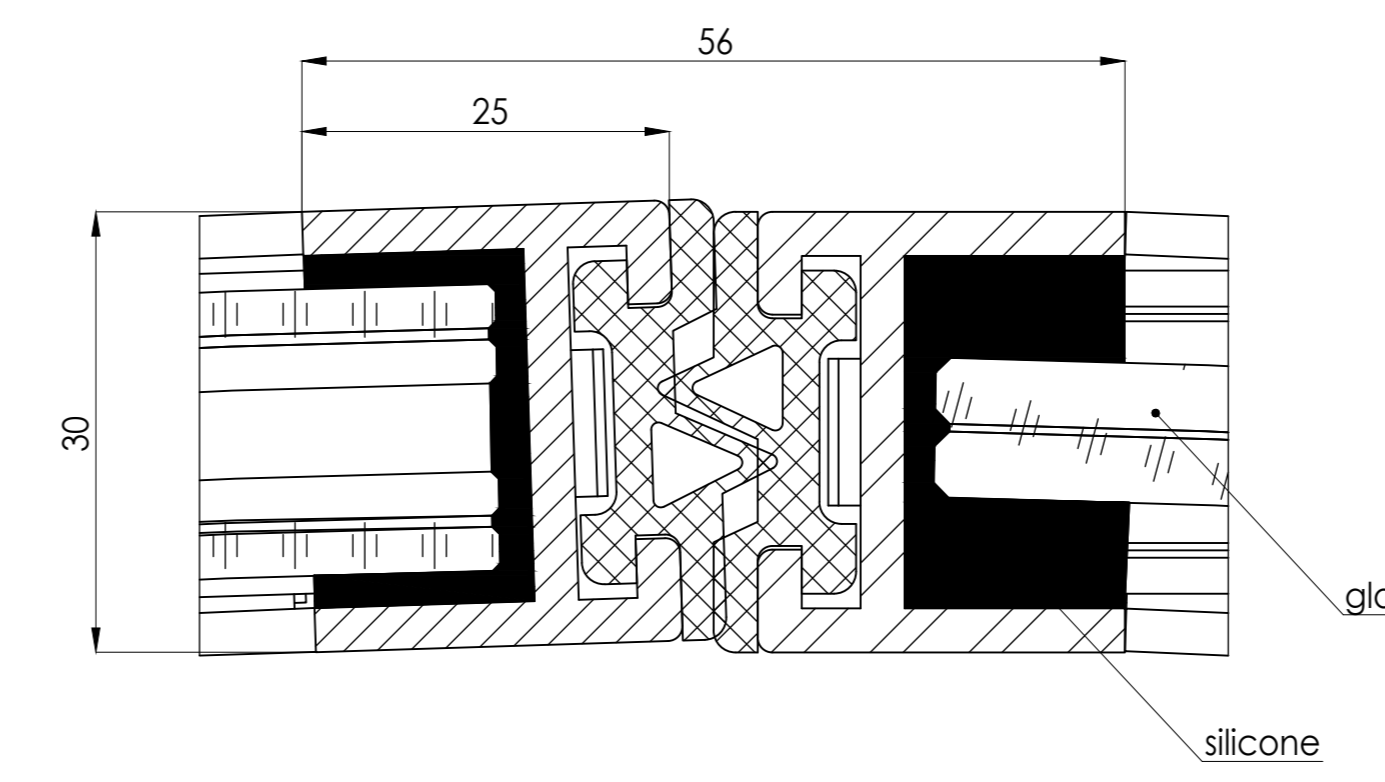

F  
(2:1)

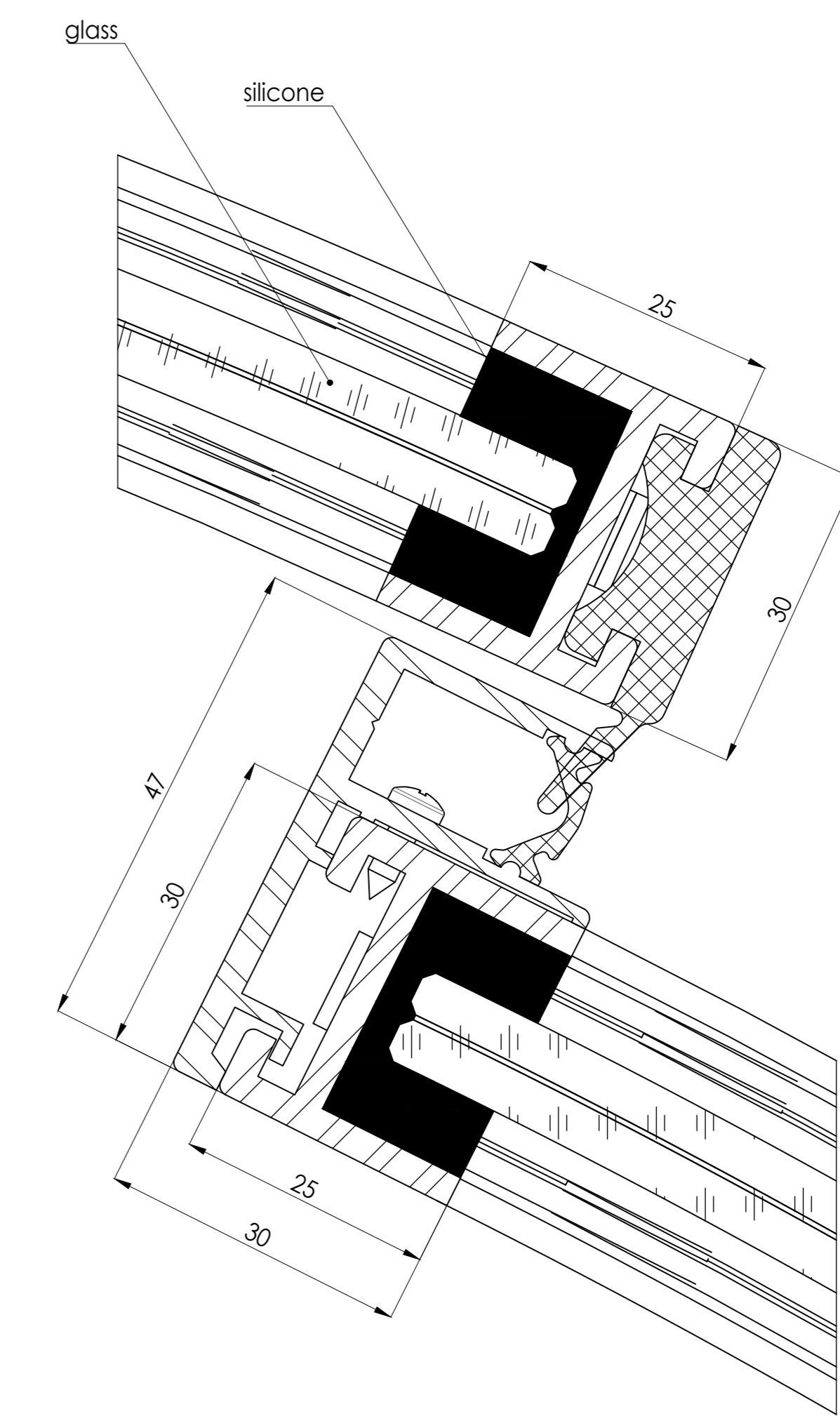

G  
(2:1)

(Facade connection to be defined by customer)



### Floor guide

Top view floor ring

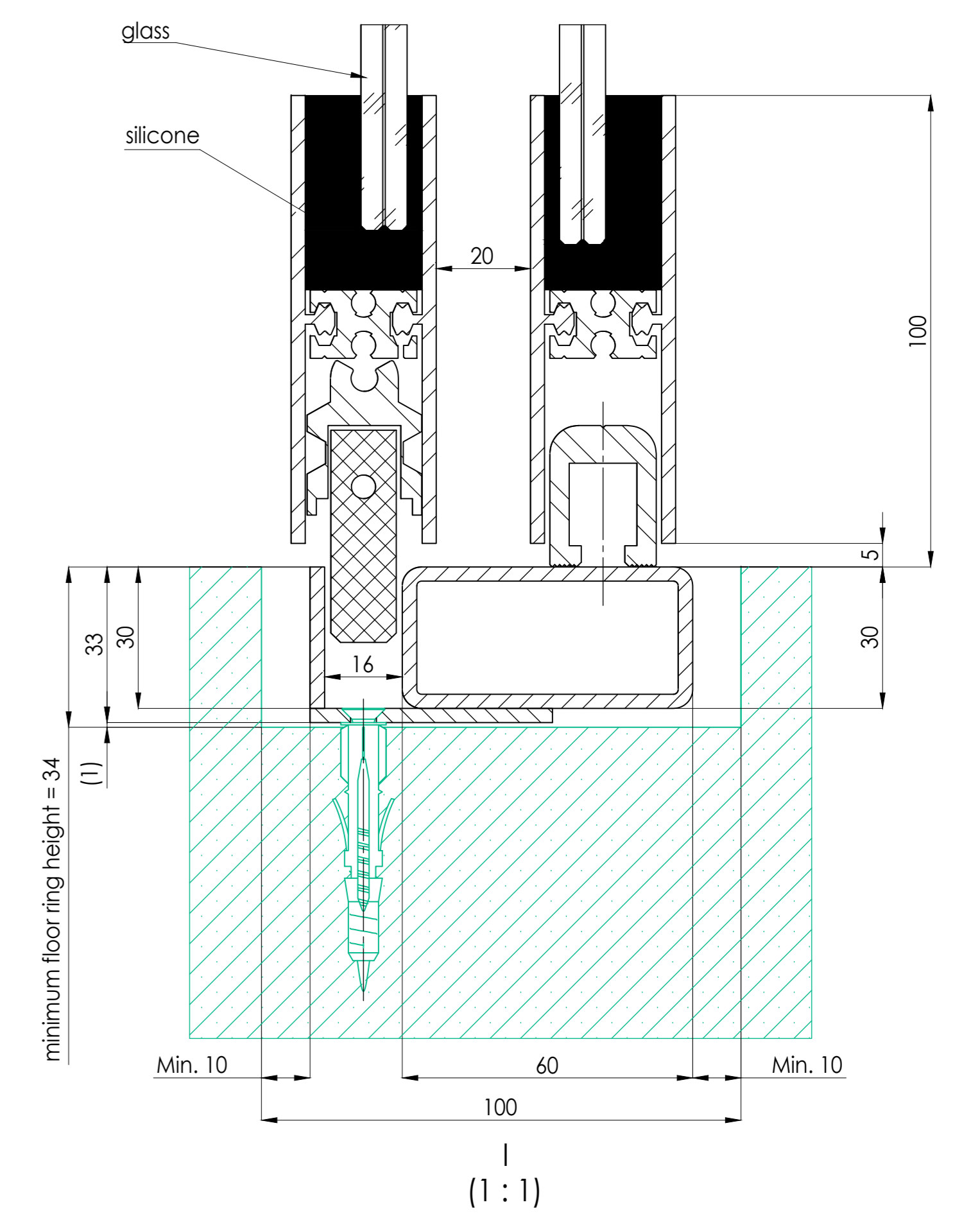
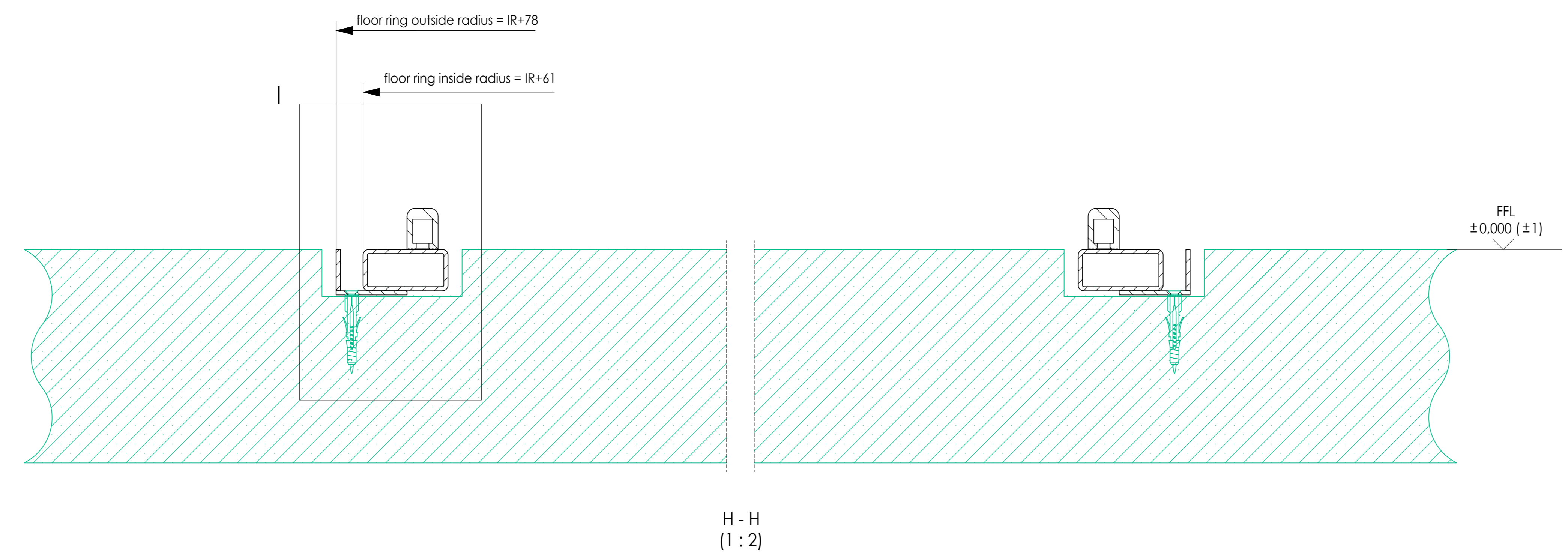
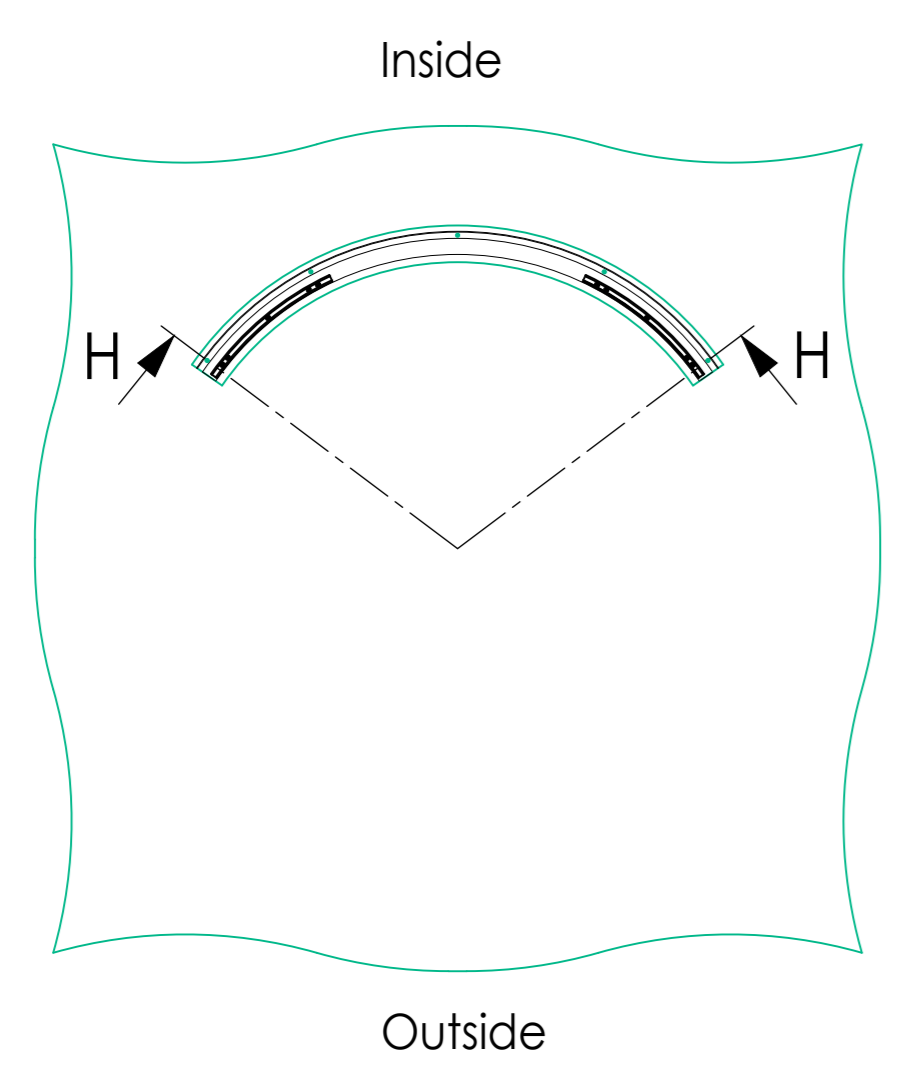

Top view floor guide rail

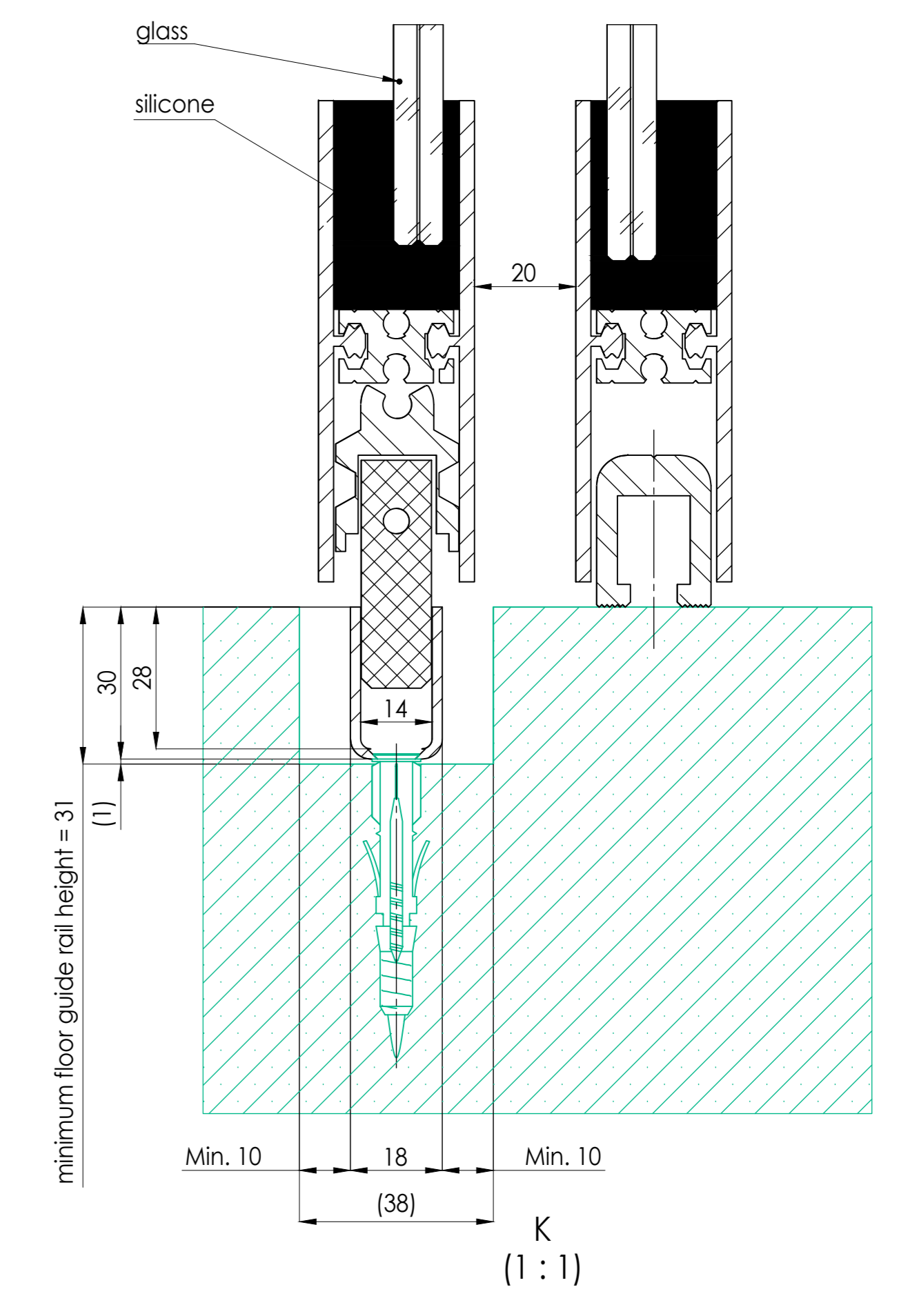
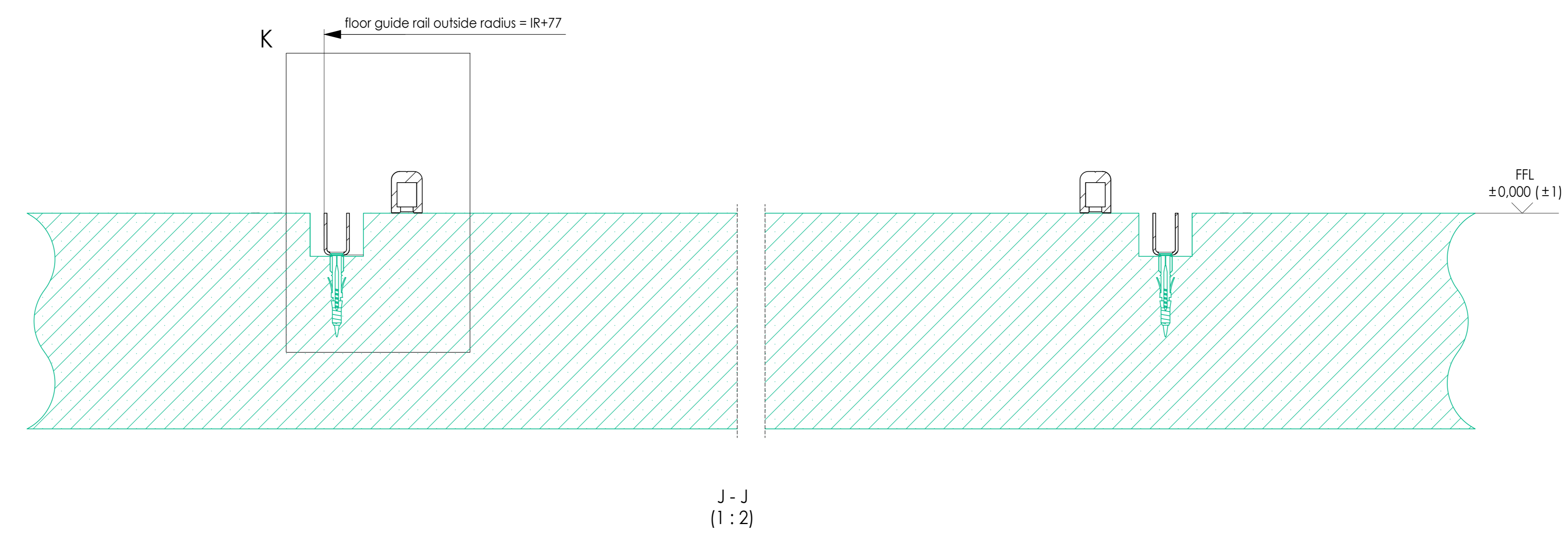
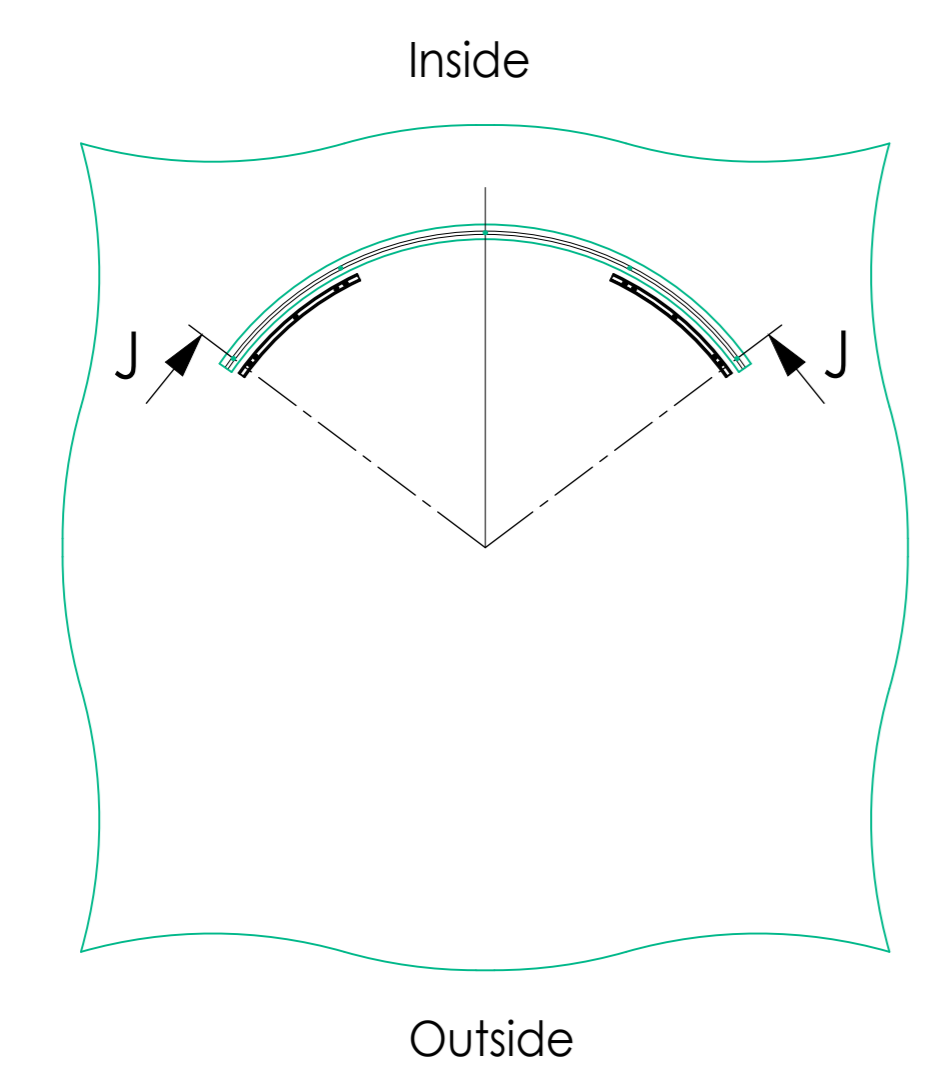

Top view finished floor

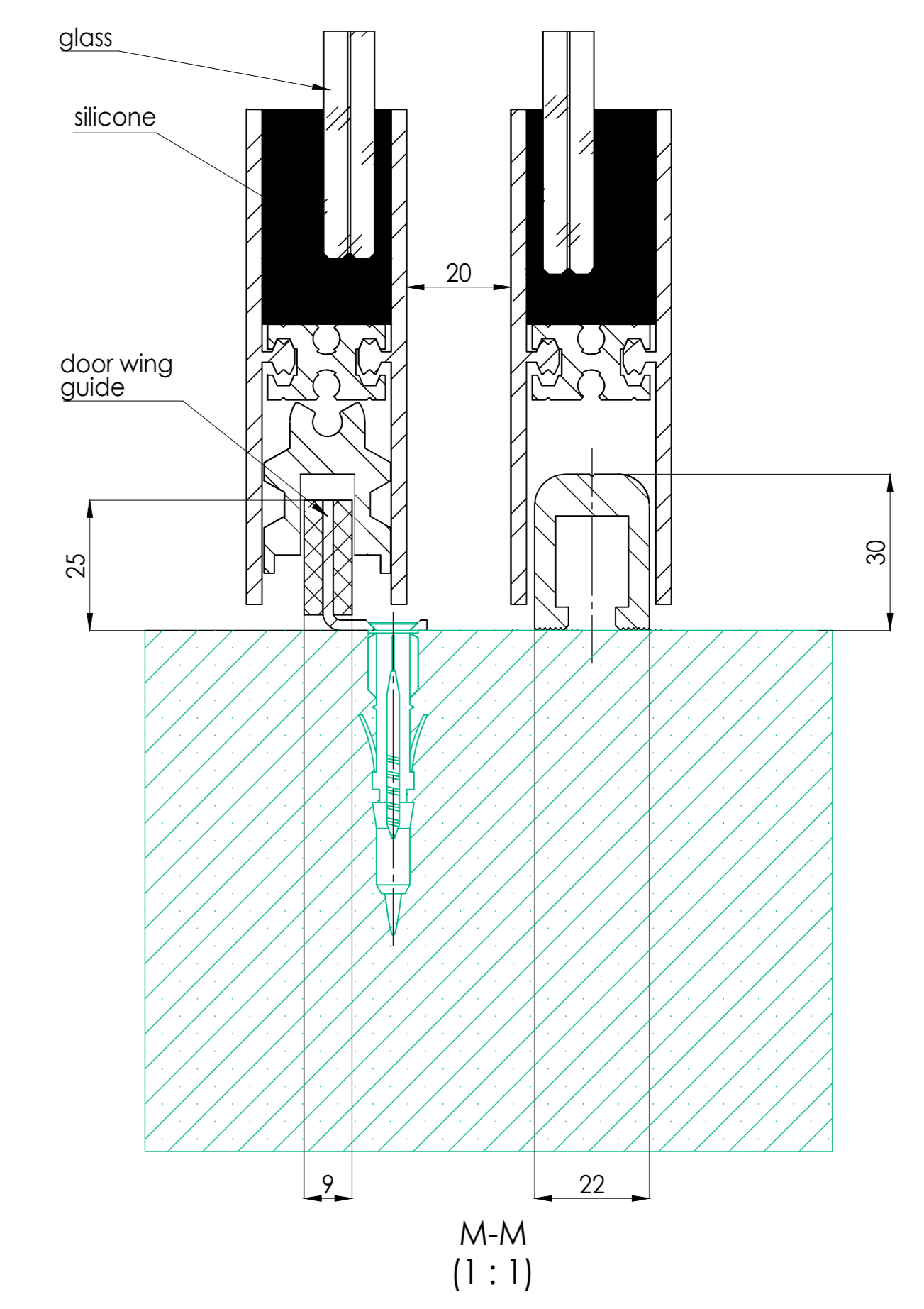
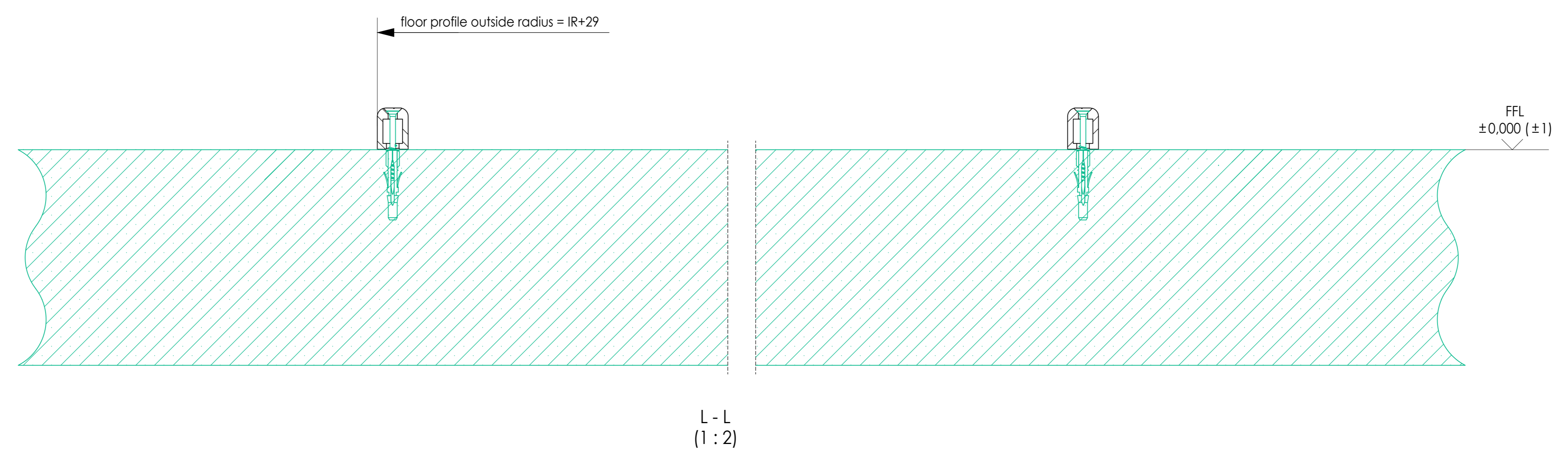
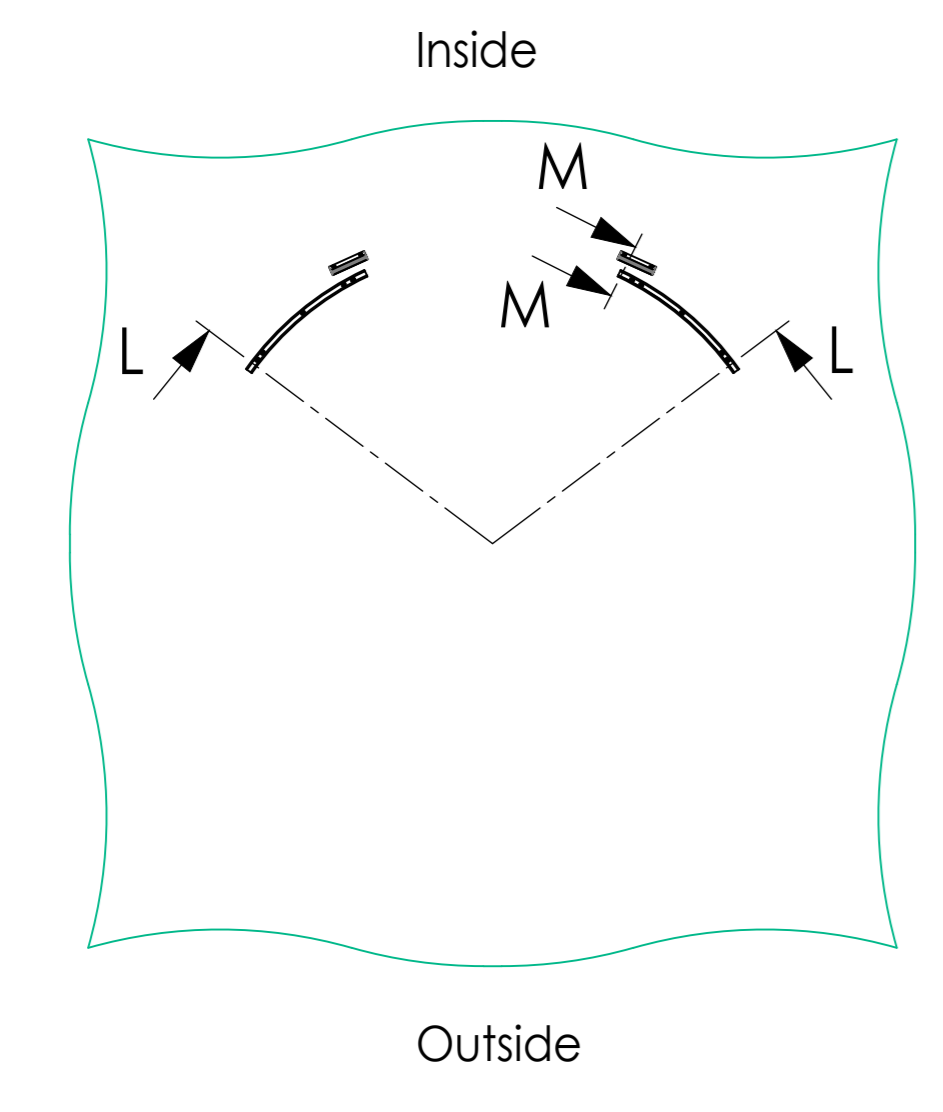

© 2022 record. All rights reserved. This drawing is the property of record. No part of this drawing may be reproduced, stored in a retrieval system, or transmitted in any form or by any means, electronic, mechanical, photocopying, recording, or by any information storage and retrieval system, without the prior written permission of record.

Surface treatment	Material	Remark
General tolerance	Prog. method	All components marked in green are to be checked before the customer.
ISO 2768	Scale 1:20	
	Drawn HNU	Date 2022-11-18
		Status Approved
	Description CURVED Concave - ALU 30 [mm]	Rev. A
		Size AO
		Sheet 3 (3)
		Drawing No.